

Total No. of Questions : 4]

SEAT No. :

PF251

[Total No. of Pages : 2

Apr-26/SE/Insem-310

S.E. (Robotics & Automation Engineering) (Insem)

CONTROL SYSTEM ENGINEERING

(2019 Pattern) (Semester-IV) (Theory) (211509)

Time : 1 Hour]

[Max. Marks : 30

Instructions to the candidates:

- 1) Answer Q.1 or Q.2 and Q.3 or Q.4.
- 2) Figures to the right indicate full marks.
- 3) Neat Diagram must be drawn wherever necessary.
- 4) Assume suitable data if necessary.

Q1) a) Define Control System. Explain the close loop control system with the help of one example. [8]

b) Define transfer function. What are the different methods used to obtain transfer function explain any one method. [7]

OR

Q2) a) Define the following terms: [8]

- i) Source Node
- ii) Sink Node
- iii) Forward path
- iv) Feedback loop

b) Find overall transfer function of control system using block diagram reduction method. [7]

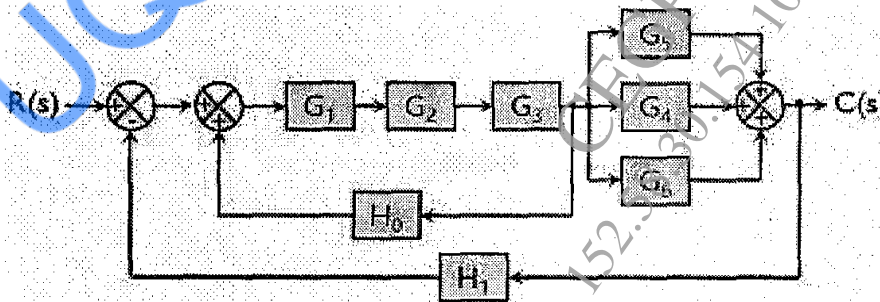

P.T.O.

**Q3) a)** Consider unity feedback system with open loop transfer function  $G(S)=16/S(S+4)$ . Determine time domain specification of closed loop system. [8]

b) Write short note on Standard Test Signals. [7]

OR

**Q4) a)** Write short note on PI, PD and PID controller. [8]

b) Write short note on static error coefficient. [7]

