

Total No. of Questions : 4]

SEAT No. :

PC-71

[Total No. of Pages : 2

[6360]-73

T.E. (Mechanical/Mechanical- S.W) (Insem.)

DESIGN OF MACHINE ELEMENTS

(2019 Pattern) (Semester - I) (302043)

Time : 1 Hour]

[Max. Marks : 30

Instructions to the candidates :

- 1) Answer Q.1 or Q.2, Q.3 or Q.4.
- 2) Neat diagrams must be drawn wherever necessary.
- 3) Figures to the right indicate full marks.
- 4) Assume suitable data wherever necessary.

Q1) a) Explain the steps for design of Cotter Joint. [6]

- b) A knuckle joint is subjected to an axial load of 25kN. It is made of Plain carbon steel 45C8 ( $S_{yt} = 380 \text{ N/mm}^2$ ). Design the joint with factor of safety 2.5. Assume the compressive strength of the material to be 20% more than tensile strength. Allowable shear stress is 0.517 of the allowable tensile stress. [9]

OR

Q2) a) Explain Lever, its types with neat sketch and applications. [6]

- b) A hollow circular column carries a projecting bracket. Which supports a load of 25kN as shown in Figure 1. The distance between the axis of the column and load is 500 mm. The inner diameter of the column is 0.8 times of the outer diameter. The column is made of steel FeE200 ( $S_{yt} = 200 \text{ N/mm}^2$ ) and the factor of safety is 4. The column is to be designed on the basis of maximum tensile stress and compression is not the criterion of failure. Determine the dimensions of the cross section of the column. [9]

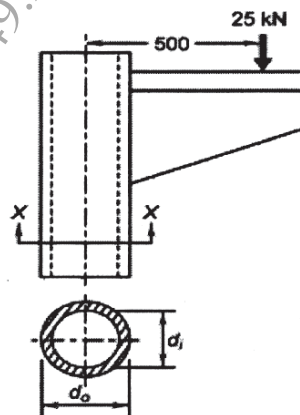

Fig:1 (Q 2- b)

P.T.O.

- Q3) a)** Explain the design Procedure for Flexible Coupling. [9]
- b)** Compute diameter of bolt for rigid coupling is used to transmit 20 kW power at 720 rpm. There are four bolts and the pitch circle diameter of the bolts is 125 mm. The bolts are made of steel 45C8 ( $S_{yt} = 380 \text{ N/mm}^2$ ) and the factor of safety is 3. Assume that bolts are finger tight in reamed and ground holes. Permissible stress is taken as 0.577 times yield stress. [6]

OR

- Q4) a)** Explain the following keys with suitable sketch [6]
- Sunk Key
  - Saddle Key
  - Kenndey key
- b)** The layout of an intermediate shaft of a gear box supporting two spur gears B and C is shown in Figure 2. The shaft is mounted on two bearings A and D. The pitch circle diameters of gears B and C are 900 and 600 mm respectively. The material of the shaft is steel FeE 580 ( $S_{ut} = 770$  and  $S_{yt} = 580 \text{ N/mm}^2$ ). The factors  $k_b$  and  $k_t$  of ASME code are 1.5 and 2.0 respectively. Determine the shaft diameter using the ASME code. Assume that the gears are connected to the shaft by means of keys thus permissible shear stress is  $103.95 \text{ N/mm}^2$ . [9]

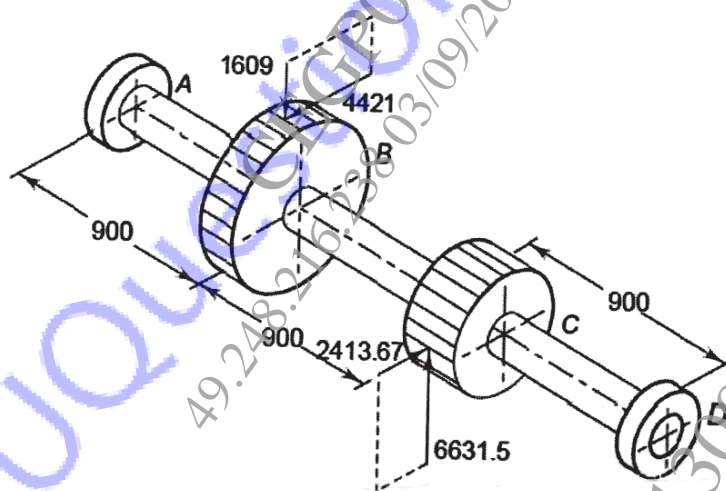

Figure 2 (Q4.b)

