

Total No. of Questions : 10]

SEAT No. :

P3343

[Total No. of Pages : 4

[5353]-513

T.E. (Mechanical/Automobile)

THEORY OF MACHINE - II

(2015 Pattern)

Time : 2½ Hours]

[Max. Marks : 70

Instructions to the candidates:

- 1) Answer Q.1 or 2, 3 or 4, 5 or 6, 7 or 8 and 9 or 10.
- 2) Neat diagrams must be drawn wherever necessary.
- 3) Figures to the right indicate full marks.
- 4) Use of calculator is allowed.
- 5) Assume suitable data wherever necessary.

Q1) a) The number of teeth on each of the two equal spur gear in mesh is 42. The teeth have 20° involute profile and the module is 6mm. If the arc of contact is 1.80 times the circular pitch, find the addendum. [6]

b) Explain the significance of helix angle and pressure angle in gears. [4]

OR

Q2) a) Derive an expression for virtual number of teeth and pitch circle diameter of equivalent spur gear. [6]

b) Draw and explain force analysis of spiral gears [4]

Q3) a) An internal wheel B with 90 teeth is keyed to a shaft F. The fixed internal wheel C with 94 teeth is concentric with B. A compound wheel D-E gears with two internal wheels. D has 32 teeth and gears with C, while E gears with B. The compound wheel revolves freely on a pin which project from a disc keyed to shaft A, co-axial with shaft F. All the wheels have same module. What will be the speed of shaft F if the shaft A rotates at 900 rpm? If the power supplied at A is 6 kW, what is the holding torque on the internal gear C? [8]

b) Write any four types of special bevel gears. [2]

OR

P.T.O.

- Q4) a)** An aircraft engine drives a propeller through a reduction drive as shown in figure.1. The gears 1, 2, 3 and 4 have 48, 27, 45, 120 teeth respectively. Find the propeller speed in magnitude and direction if the engine makes 2500 rpm. [8]

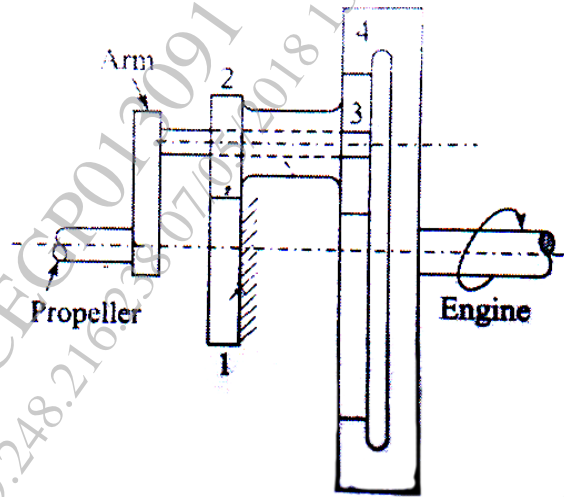

Figure.1

- b) Explain the effect of module on size of tooth. [2]
- Q5) a)** Derive an expression for displacement, velocity, acceleration and jerk for 3-4-5 polynomial advanced cam and also sketch the curves. [10]
- b) An eccentric cam of eccentricity 3.75 cm drives a follower of mass 1.75 kg. The spring holding the follower against the cam has stiffness of 24N/mm and has initial compression of 3.125 cm. Find out the speed of cam in rpm. Also find out maximum usable speed of cam without jump. [6]

OR

- Q6)** The following data is related to a cam profile, in which the follower moves with SHM during the lift and returning it with uniform acceleration and deceleration, acceleration being 0.5 times the deceleration. Minimum radius of cam = 30mm, Roller radius = 10mm, Lift of follower = 45mm, Angle of Ascent = 70°, Angle of decent = 120°, Angle of dwell between ascent and decent = 45°, Speed of cam = 300 rpm. Draw the cam profile, pitch circle and also determine maximum velocity, maximum acceleration during lift. [16]

- Q7) a)** A four bar mechanism is to be synthesized by using precision points to generate the function $y = 2x^2 - x$ for the range $1 \leq x \leq 4$. Assuming 30° starting position and 120° finishing position for input link and 70° starting and 160° finishing position for output link. Find out values of x , y , θ (input angles) and ϕ (output angles) corresponding to the 3 precision points with Chebychev spacing. If the length of longest and smallest link is 10 cm and 4 cm respectively. Synthesize the mechanism by using method of inversion. Find the length of remaining links. [10]
- b) Discuss analytical synthesis using kinematic coefficient in four bar mechanism. [6]

OR

- Q8) a)** Design a four bar linkage is to satisfy the following conditions : [10]

$$\Phi, \text{ input angle} = 60^\circ; \frac{d\phi}{dt} = \frac{3^\circ}{\text{sec}}; \frac{d^2\phi}{dt^2} = -1^\circ/\text{sec}$$

$$\Psi, \text{ output angle} = 90^\circ; \frac{d\psi}{dt} = \frac{2^\circ}{\text{sec}}; \frac{d^2\psi}{dt^2} = 0$$

- b) Explain the following terms (Any 3) : [6]
- i) Dimensional Synthesis
 - ii) Function generation
 - iii) Body guidance
 - iv) Structural errors

- Q9) a)** A ship is propelled by a turbine having a mass of 6000kg and a speed of 2400 rpm. The direction of rotation of rotor is anticlockwise when viewed from the bow end. The radius of gyration of rotor is 450mm. Determine gyroscopic effect when:

- i) Ship is steering to the left in a curve of 60m radius at a speed of 18 knots (Take 1knot=1855m/hr).
- ii) Ship is pitching in SHM with bow descending with maximum velocity. The time period of pitching is 18 seconds and the ship pitches 7.5° above and 7.5° below the normal position.
- iii) Ship is rolling and at the instant, its angular velocity is 0.035 rad/sec counterclockwise when view from stern end.

iv) Also find the maximum angular acceleration during pitching [14]

- b) Compare stepped and stepless regulation. [4]

OR

- Q10)**a) A four wheel vehicle of mass 2500kg has a wheel base 2.5m, track width 1.5m and height of centre of gravity 0.6m above the ground level and lies at 1m from the front axle. Each wheel has an effective diameter of 0.8m and a moment of inertia of 0.8 kg-m². The drive shaft, engine flywheel and transmission rotating at four times the speed of road wheels, in clockwise direction when view from the front, and is equivalent to mass of 80 kg having a radius of gyration of 100mm. If the wheel is taking a right turn of 60 m radius at 60 kmph, find the load on each wheel. The engine axis is along the longitudinal axis of the vehicle. [12]
- b) Discuss in brief PIV transmission [6]

ॐॐॐ