

Total No. of Questions—8]

[Total No. of Printed Pages—4+1

Seat No.	
-------------	--

[5152]-515

S.E. (Mechanical/Automobile/Sandwich) (First Semester)

EXAMINATION, 2017

STRENGTH OF MATERIALS

(2015 PATTERN)

Time : Two Hours

Maximum Marks : 50

N.B. :— (i) Neat diagrams must be drawn wherever necessary.

(ii) Figures to the right side indicate full marks.

(iii) Use of calculator is allowed.

(iv) Assume suitable data if necessary.

1. (a) Determine the stress in each section of the circular bar as shown in figure when subjected to an axial tensile load of 20 kN. [4]

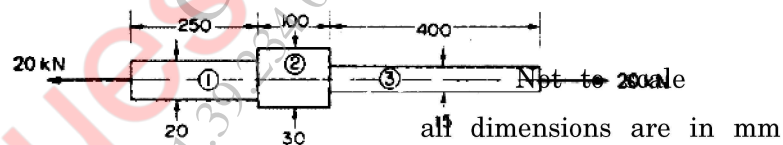

- (b) Draw SF and BM diagrams for the given beam. [8]

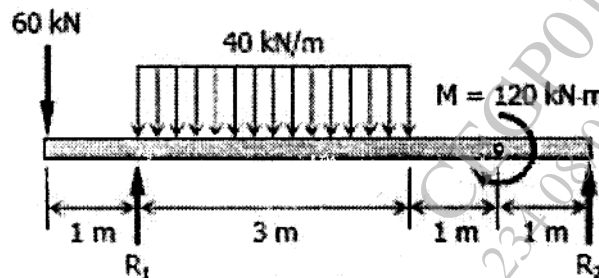

P.T.O.

Or

2. (a) The composite bar as shown in figure is rigidly fixed at the ends A and B. Determine the reaction developed at ends when the temperature is raised by  $18^{\circ}\text{C}$ . Given  $E_{\text{Al}} = 70 \text{ kN/mm}^2$ ,  $E_{\text{s}} = 200 \text{ kN/mm}^2$ ,  $\alpha_{\text{Al}} = 11 \times 10^{-6}/^{\circ}\text{C}$ ,  $\alpha_{\text{st}} = 12 \times 10^{-6}/^{\circ}\text{C}$  [6]

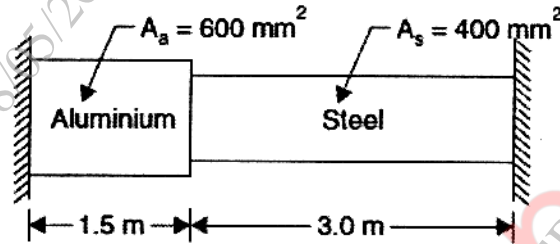

- (b) Derive SF and BM equations and then draw SFD and BMD of a given beam. [6]

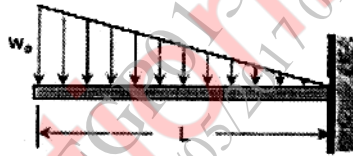

3. (a) A symmetrical H section with height 120 mm, width 120 mm and thickness 20 mm is used as a simply supported beam and carries UDL of 60 kN/m over a span of 3 m. Determine shear stress at the neutral axis of H section if moment of inertia about neutral axis is  $5.75 \times 10^6 \text{ mm}^4$ . [6]
- (b) Determine slope at the simple supports  $R_1$  and  $R_2$  of given overhang beam in terms of EI. [6]

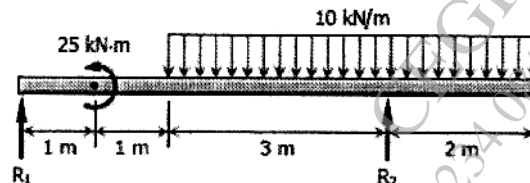

Or

4. (a) Simply supported beam with point load  $W$  at the center and length 2 m. The cross-section of beam is T section (flange 100 mm  $\times$  12 mm and web 38 mm  $\times$  12 mm). The allowable bending stress in tension and compression are 100 MPa and 150 MPa. Find safe load  $W$ . [6]
- (b) A cantilever beam of length 4 m and UDL of 60 N/m. Determine strain energy stored in the beam. Assume  $I = 1 \times 10^{-6} \text{ m}^4$  and  $E = 200 \text{ GPa}$ . [6]
5. (a) A solid circular bar 25 m long and 120 mm was found to be extended 1.2 mm under tensile load of 52 kN. Now the same bar is used as a strut. Determine critical load and safe load taking FOS = 3 with the following end conditions :
- (i) Both ends fixed, and
- (ii) One end fixed and other end hinged. [6]
- (b) A compound shaft consisting of a steel segment and an aluminum segment is acted upon by two torques as shown in Fig. Determine the maximum permissible value of  $T$  subject to the following conditions:  $\tau_{st} = 83 \text{ MPa}$ ,  $\tau_{Al} = 55 \text{ MPa}$ , and the angle of rotation of the free end is limited to  $6^\circ$ . For steel,  $G = 83 \text{ GPa}$  and for aluminum,  $G = 28 \text{ GPa}$ . [7]

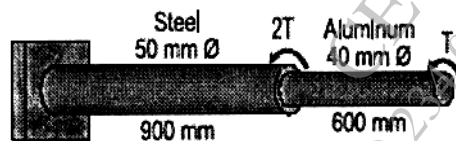

Or

6. (a) The compound shaft shown in Fig. is attached to rigid supports. For the bronze segment AB, the diameter is 75 mm,  $\tau \leq 60$  MPa, and  $G = 35$  GPa. For the steel segment BC, the diameter is 50 mm,  $\tau \leq 80$  MPa, and  $G = 83$  GPa. If  $a = 2$  m and  $b = 1.5$  m, compute the maximum torque  $T$  that can be applied. [7]

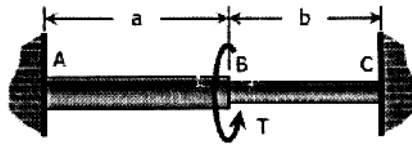

- (b) The rod PQ of length  $L$  and flexural rigidity  $EI$  is hinged at both ends. For what minimum force  $F$  is it expected to buckle? [6]

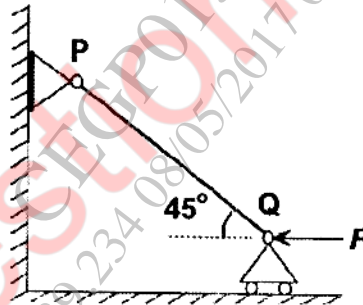

7. (a) State of stress for an element of unit thickness is shown in Figure. Find the normal stress and shear stress that must act on an inclined dotted plane to keep the element in equilibrium and show the result on inclined plane with proper orientation. [7]

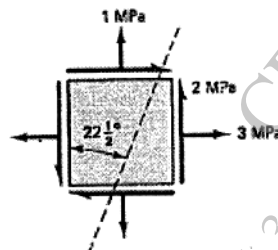

- (b) At a certain position of circular structure of diameter  $d$  is subjected to shear force of 10 kN together with an axial tensile load of 20 kN. If the allowable working stress is 67.5 MPa. Estimate the magnitude of ' $d$ ' required according to the maximum principal stress theory. [6]

Or

8. For the given state of plane stress [13]
- (a) Construct Mohr's circle with proper scale on graph paper.
  - (b) Determine principal stresses and its orientation from Mohr's circle.
  - (c) Determine shear stress and normal stress on maximum shear plane and its orientation from Mohr's circle.
  - (d) Represent all the stresses and plane orientations in Mohr's circle.

