

[5931]-1008

F.E. (All)

ENGINEERING MECHANICS

(2019 Pattern) (Semester - I) (101011)

Time : 1 Hour]

[Max. Marks : 30

Instructions to the candidates:

- 1) Answer Q.1 or Q.2, Q.3 or Q.4
- 2) Figures to the right indicate full marks.
- 3) Assume suitable data, if necessary.
- 4) Use of electronic pocket calculator is allowed in the examination.
- 5) Use of cell phone is prohibited in the examination hall.

- Q1) a) Determine magnitude of the resultant for the force system as shown in Fig. 1A, w.r. to 'A'. Also determine the horizontal distance from point 'A', where the resultant cuts the line ABC. Comment on whether it cuts on right hand side or left hand side of point 'A'. [6+2+2]

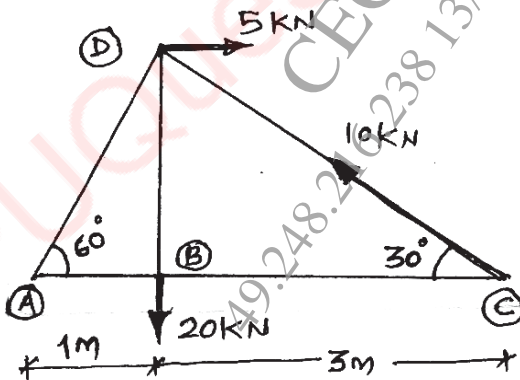

Fig. 1A

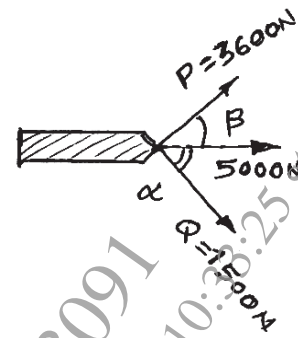

Fig. 1B

- b) Resultant force $R = 5000$ N has two component forces ' P ' = 3600 N and ' Q ' = 1500 N as shown. Determine direction of component forces ' P ' and ' Q ' w.r. to resultant force ' R '. [5]

OR

P.T.O.

- Q2) a) State Varignon's theorem and determine the magnitude and sense of a horizontal force 'P' to be applied at 'B' which will keep the vertical rod ABCD in equilibrium as shown in Fig. 2A. Take length AB = BC = CD = 1.8 m. [2+5]

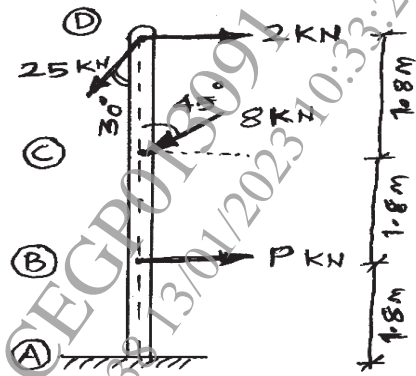

Fig. 2A

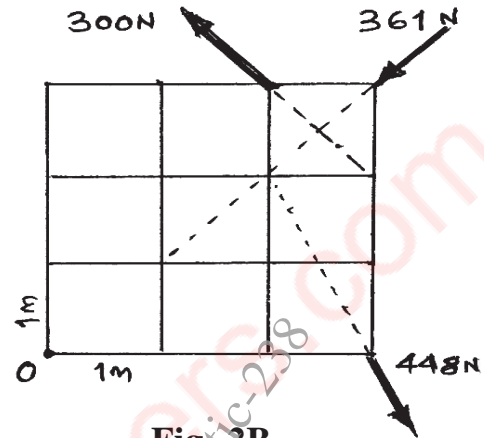

Fig. 2B

- b) Determine the magnitude, direction and position of the resultant force for the given three forces acting as shown in Fig.2B, w.r. to 'O'. [2+2+2+2]

- Q3) a) Analyze and locate the position of centroid for the plane lamina as shown in Fig. 3A, w.r. to 'A'. Also determine the moment of inertia of the shaded portion with respect to x-x axis (horizontal) passing through the centroid. [5+4]

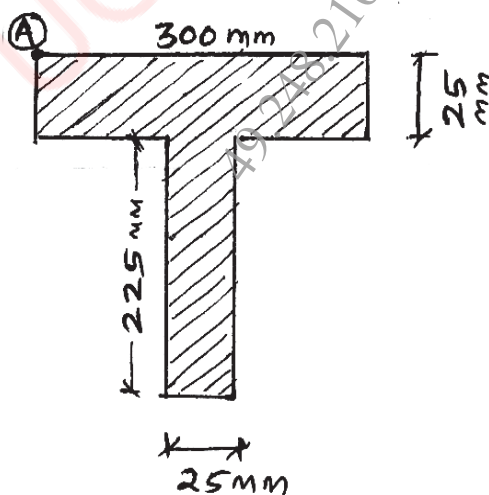

Fig. 3A

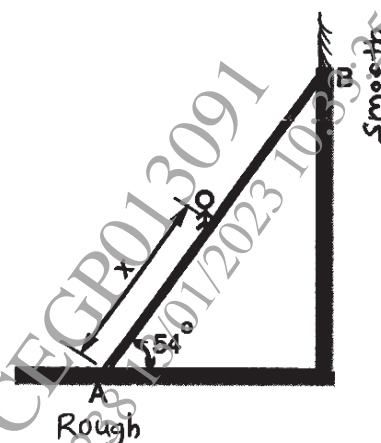

Fig. 3B

- b) The uniform ladder **AB** has a length of 6 m and a mass of 16 kg resting at 54° with horizontal floor. End **A** of ladder is resting on rough horizontal floor and end **B** rests against a smooth vertical wall as shown in **Fig. 3B**. A man of mass 65 kg has to climb this ladder. At what position from the base will he induce slipping? Take coefficient of static friction $\mu_s = 0.34$ between horizontal floor and ladder. [6]

OR

- Q4) a) Analyze and locate the position of centroid for the plane lamina as shown in **Fig. 4A**, w.r.to 'O'. Also determine the moment of inertia of the shaded portion with respect to y-y axis (vertical) passing through the centroid. [4+5]

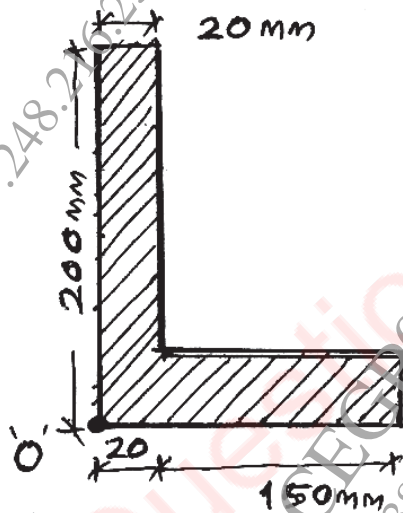

Fig. 4A

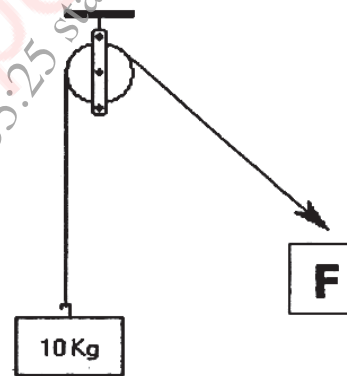

Fig. 4B

- b) A block of 10kg hanging through a inextensible cable and kept in rest by applying a force of magnitude ' $F = 1.5 \text{ kg}$ ' on other side of the cable, which is passing through the rough pulley as shown in the **Fig. 4B**. Determine (i) the lap angle between cable and pulley required to keep the block in rest; (ii) the number of turns required to wound the cable on pulley. Take coefficient of static friction $\mu_s = 0.30$ between pulley and cable. [6]

