

Total No. of Questions—8]

[Total No. of Printed Pages—4

Seat No.	
----------	--

[5352]-532

S.E. (E & TC/Electronics) (I Semester) EXAMINATION, 2018

ELECTRONIC DEVICES AND CIRCUITS

(2015 PATTERN)

Time : Two Hours

Maximum Marks : 50

N.B. :— (i) Answer Q. 1 or 2, 3 or 4, 5 or 6, 7 or 8.

(ii) Neat diagram must be drawn wherever necessary.

(iii) Use of logarithm tables, slide rule, Mollier charts, electronic pocket calculator and steam table is allowed.

(iv) Assume suitable data, if necessary.

1. (a) Explain the following terms with respect to JFET : [6]

(i) Pinch off voltage (V_p)

(ii) Cut-off voltage ($V_{GS(off)}$)

(iii) Forward transconductor (g_m).

(b) For the circuit shown in figure 1. Calculate I_{DQ} , V_{DSQ} and V_D . [6]

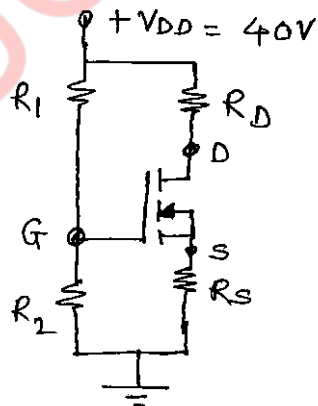

Assume :

$$R_1 = 22 \text{ M}\Omega, R_D = 3 \text{ k}\Omega$$

$$R_2 = 18 \text{ M}\Omega, V_{TN} = 3 \text{ V}, R_S = 0.82 \text{ k}\Omega$$

$$K_n = 0.12 \text{ mA/V}^2$$

$$V_{GS} = 10.48 \text{ V}$$

(Figure 1)

P.T.O.

Or

2. (a) Draw and explain the small signal mode of the JFET. [6]
(b) Explain the following non-ideal voltage current characteristics of EMOSFET :
(i) Finite output resistance
(ii) Body effect
(iii) Subthreshold conduction. [6]

3. (a) Draw the common source E-MOSFET amplifier and explain its modes of operation in detail. [7]
(b) Draw and explain the working of MOSFET as current sink and source. [6]

Or

4. (a) For the circuit diagram shown in figure 2, calculate A_v , R_i and R_o . [7]

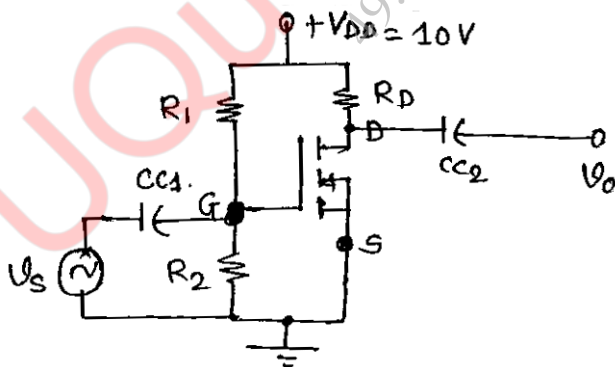

Assume :

$$R_1 = 10 \text{ M}\Omega$$

$$R_2 = 3.6 \text{ M}\Omega$$

$$K_n = 0.5 \text{ mA/V}^2$$

$$\lambda = 0.01 \text{ V}^{-1}$$

$$V_{TN} = 1.5 \text{ V}$$

(Figure 2)

- (b) Write a short note on “MOSFET as Active resistor.” [6]

5. (a) What is the effect of negative feedback on the following parameters : [8]
- (1) Gain stability
 - (2) Bandwidth
 - (3) Input impedance
 - (4) Out impedance.
- (b) Draw and explain the Hartley oscillator. Give equation for frequency of oscillation. [5]

Or

6. (a) For the circuit diagram shown in figures, calculate the β , R_{if} , R_{of} and G_{mf} . [8]

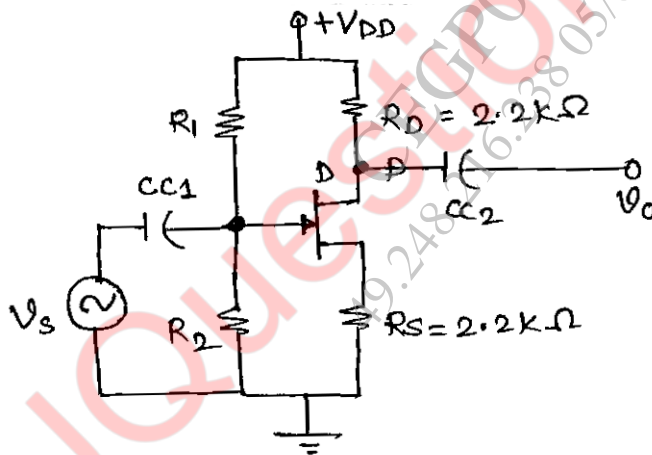

(Figure 3)

Assume :

$$R_1 = 10 \text{ M}\Omega$$

$$R_2 = 1 \text{ M}\Omega$$

$$R_D = 2.2 \text{ k}\Omega$$

$$R_S = 2.2 \text{ k}\Omega$$

$$Y_{OS} = 20 \text{ }\mu\text{s}$$

$$g_m = 2.4 \text{ MA/V}$$

- (b) State Barkhausen criteria and draw RC phase shift oscillator. [5]
7. (a) Draw and explain the internal block diagram of negative three terminal adjustable Voltage regulators. [8]

(b) Write a short note on Boost SMPS. [4]

Or

8. (a) Draw the detailed block diagram of SMPS and explain its operation. [8]

(b) Design an adjustable voltage regulator using LM 317 for output voltage from 10 to 20 V and draw the typical connection diagram.

Assume : $R_1 = 240 \Omega$ and $I_{adj} = 100 \mu A$. [4]