

Total No. of Questions : 4]

SEAT No. :

PC394

[6359]-514

[Total No. of Pages : 3

S.E. (Electronics/ E & TC) (Insem)
ELECTRICAL CIRCUITS
(2019 Pattern) (Semester - III) (204183)

Time : 1 Hour]

[Max. Marks : 30

Instructions to the candidates:

- 1) Answer Q.1 or Q.2, Q.3 or Q.4.
- 2) Neat diagram and waveforms must be drawn whenever necessary.
- 3) Figures to the right indicate full marks.
- 4) Use of nonprogrammable calculator is allowed.
- 5) Assume suitable data, if necessary.

- Q1) a) Using super mesh analysis technique determine the current in the 5Ω resistor of the network shown in Fig. [6]

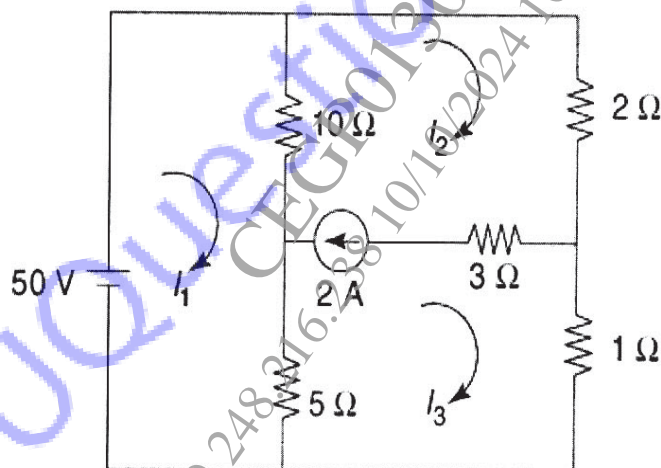

- b) What is source transformation, explain with neat diagrams. [3]
- c) Using source transformation technique, replace the circuit between A and B in figure with a voltage source in series with a single resistor. [6]

P.T.O.

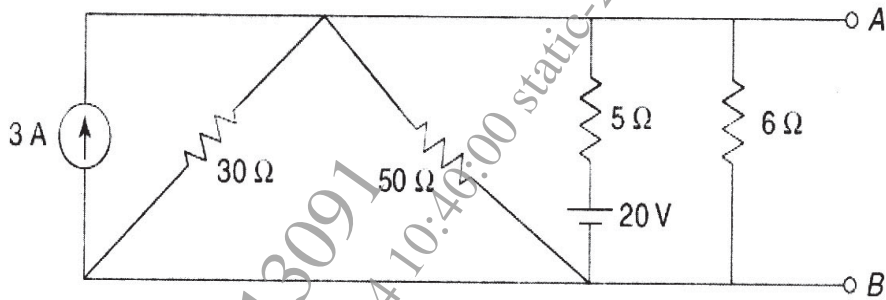

OR

- Q2) a) State and explain super position theorem. [3]
 b) Using super position theorem find the current through the 4Ω resistor. [6]

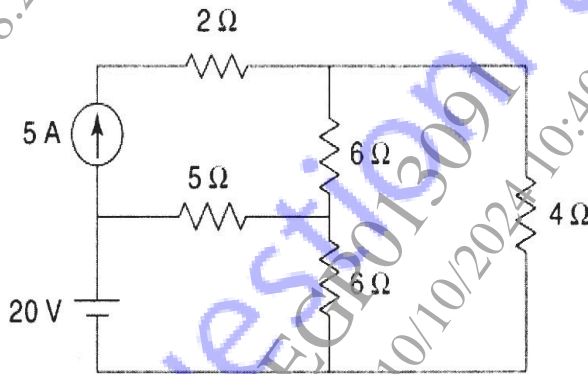

- c) What is super node. Determine the current in the 5Ω resistor using super node technique, for the network shown in Fig. [6]

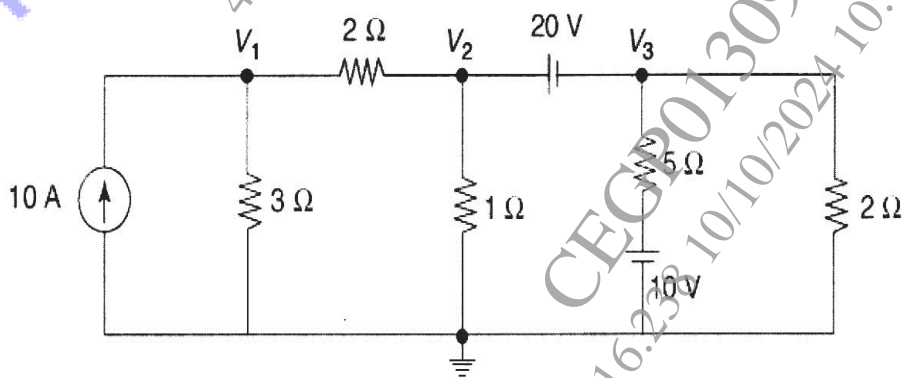

- Q3) a)** Derive the equation for the Complementary Solution for voltage across the capacitor $v_c(t)$ for Source Free RC Circuit. Draw natural Response of the Circuit for various values of t . [8]
- b)** In the network shown below, the switch is closed at $t = 0$. With the capacitor uncharged, find value for i , di/dt and d^2i/dt^2 at $t = 0^+$. [7]

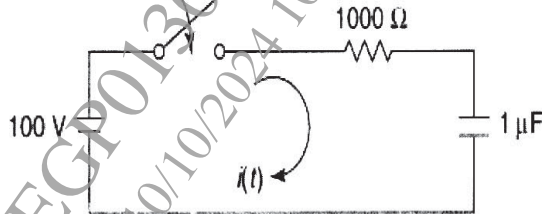

OR

- Q4) a)** Obtain the characteristics equation for series R L C Circuit and explain following cases of response with neat diagrams. [8]
- i) Over damped response
 - ii) Critically damped response
 - iii) Under damped response
- b)** A series R-L circuit is driven by DC Voltage source V . A voltage source is connected in series circuit through a switch K which is closed at $t = 0$. find expression for current through inductor for $t > 0$. Sketch the variation of $i(t)$ against time. [7]

* * *