

Total No. of Questions : 6]

SEAT No. :

P528

[Total No. of Pages : 2

TE/Insem/APR-115
T.E.(Electrical) (Semester - II)
CONTROL SYSTEM - I
(2015 Pattern)

Time : 1 Hour]

[Max. Marks : 30

Instructions to the candidates:

- 1) Answer any one question from each pair of questions : Q.1 or Q.2, Q.3 or Q.4, Q.5 or Q.6.
- 2) Figures to the right indicate full marks.

- Q1)** a) Compare open loop system and close loop system. [4]
b) Find transfer function of given system using block diagram reduction. [6]

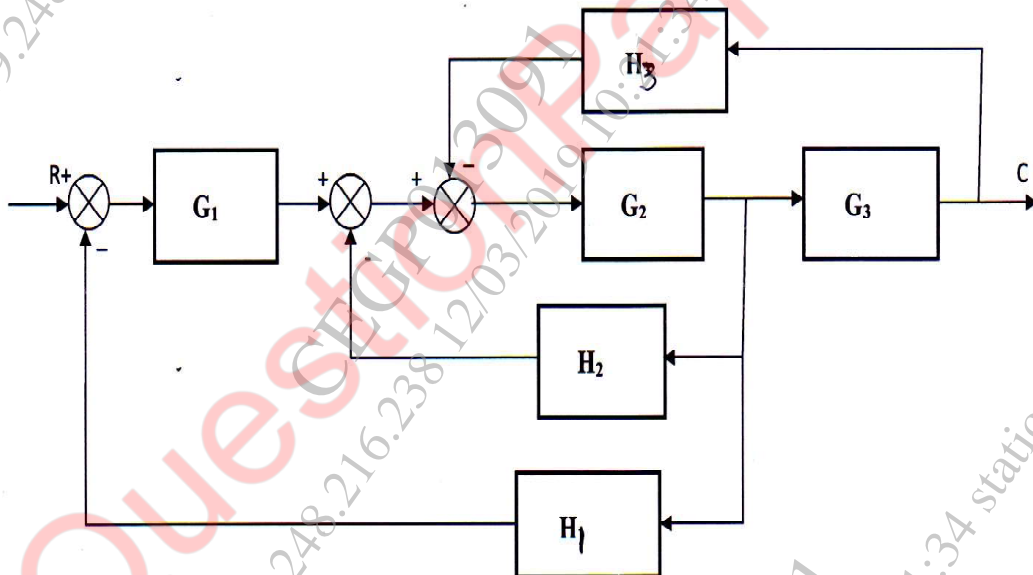

OR

- Q2)** a) Explain masons gain formula. [4]
b) Find transfer function $V_o(s)/V_i(s)$ for given electrical network. [6]

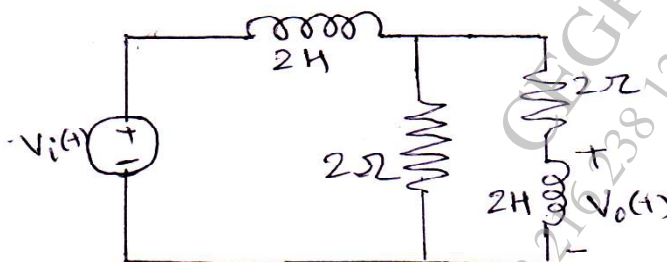

P.T.O.

- Q3) a)** Define static error coefficients. [4]
b) A unity feedback system has the following forward transfer function: [6]

$$G(s) = \frac{1000(s+8)}{(s+7)(s+9)}$$

- i) Evaluate system type, K_p , K_v , and K_a .
 ii) Steady state error for step input and ramp input

OR

- Q4) a)** For each of the following transfer functions, find its roots and draw the general form of the step response. [6]

i) $G(s) = \frac{400}{s^2 + 12s + 400}$

ii) $G(s) = \frac{900}{s^2 + 90s + 900}$

iii) $G(s) = \frac{625}{s^2 + 625}$

- b)** For a second order system find ζ , ω_n , t_s , % overshoot. [4]

$$G(s) = \frac{16}{s^2 + 3s + 16}$$

- Q5) a)** Given the unity feedback system with $G(s) = \frac{K(s+4)}{s(s+1.2)(s+2)}$ find the following: [6]

- i) The range of K that keeps the system stable
 ii) The value of K that makes the system oscillate
 iii) The frequency of oscillation when K is set to

- b)** Explain angle and magnitude criterion for Root Locus. [4]

OR

- Q6) a)** Sketch the root locus for the system with open Loop Transfer function,

$$G(s) = \frac{K(s+3)}{s(s+1)(s+2)(s+4)}$$

Find break away point, intersection with imaginary axis, K marginal. [8]

- b)** What is root locus. [2]

