

Total No. of Questions—8]

[Total No. of Printed Pages—4+1

Seat No.	
-------------	--

[5152]-548

S.E. (Electrical Engineering) (Second Semester)

EXAMINATION, 2017

NETWORK ANALYSIS

(2015 PATTERN)

Time : Two Hours

Maximum Marks : 50

N.B. :— (i) Answer Q. No. 1 or 2, Q. No. 3 or 4, Q. No. 5 or 6,
Q. No. 7 or 8.

(ii) Neat diagrams must be drawn wherever necessary.

(iii) Figures to the right indicate full marks.

(iv) Use of calculator is allowed.

(v) Assume suitable data, if necessary.

1. (a) Reduce the given network figure to a single voltage source and impedance. [6]

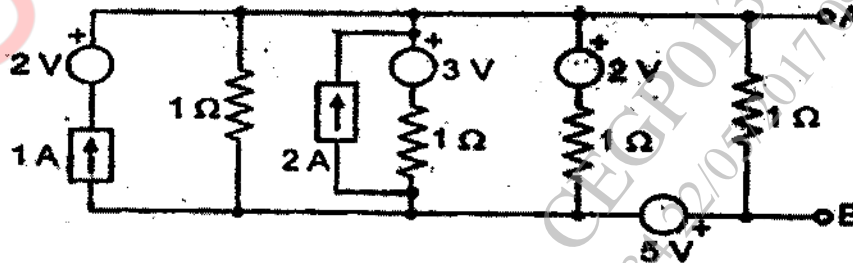

P.T.O.

- (b) In the circuit shown, find current I , using superposition theorem. [7]

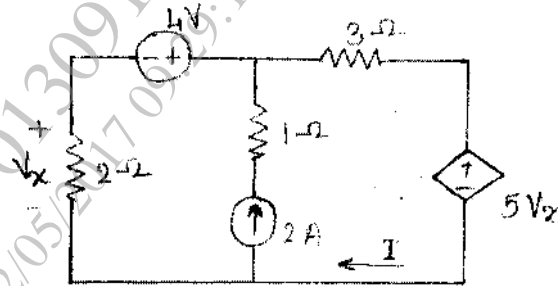

Or

2. (a) Explain the following terms in relation with network graphs : [6]
- (i) Tree
 - (ii) Cut set
 - (iii) Tie set.
- (b) Use Thevenin's theorem to calculate current through branch A-B as shown in figure below. [7]

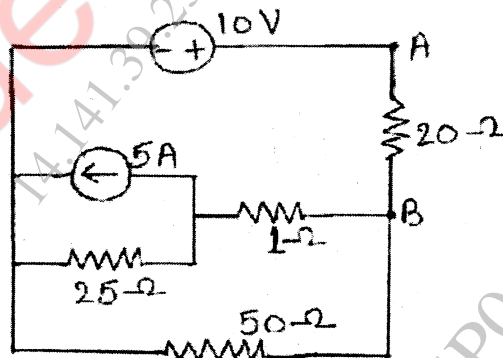

3. (a) As shown in circuit, switch K is changed from position 1 to position 2 at time $t = 0$, steady state condition reached before

switching. Find I , di/dt , d^2i/dt^2 at $t = 0^+$. [6]

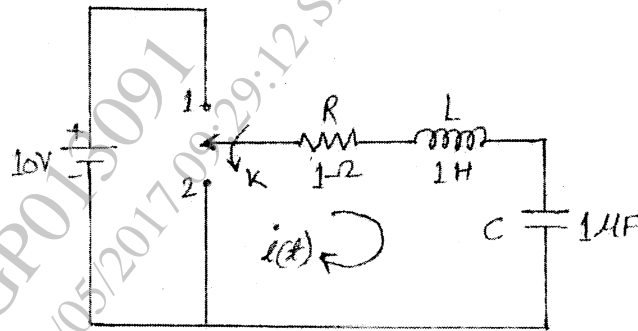

(b) Using Laplace transform find $i(t)$ in the network if initial conditions are zero. [6]

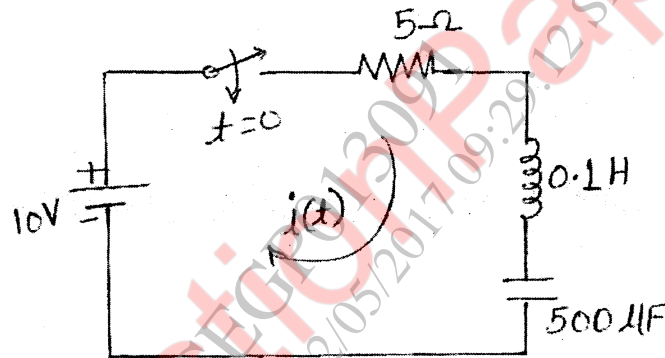

Or

4. (a) A $5\mu\text{F}$ capacitor is initially charged with $500\mu\text{C}$. At $t = 0$, the switch K is closed. Determine the voltage drop across the resistor at $t < \tau$ and at $t = \infty$. [6]

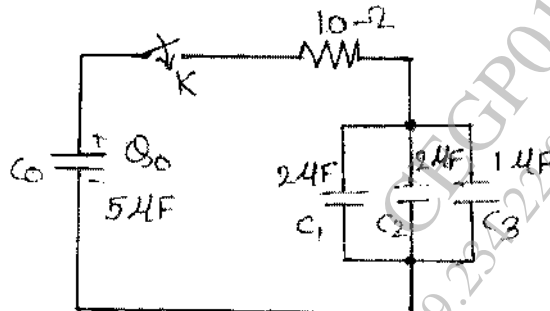

- (b) After being on position 1 for long time, the switch is thrown on position 2 at time $t = 0$, find current using Laplace Transform technique. [6]

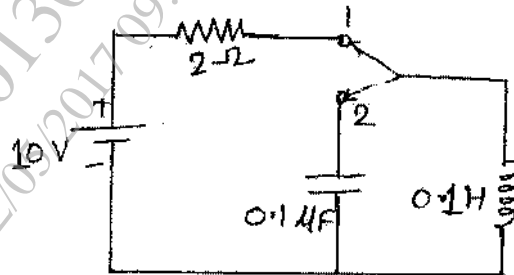

5. (a) Write a short note on location of poles and zeros on s-plane. [6]
- (b) Find Z parameters for the network shown in figure. [7]

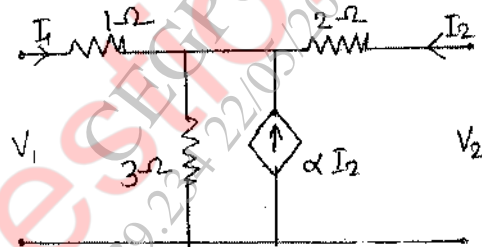

Or

6. (a) Find Transmission parameters for the network shown in figure. [6]

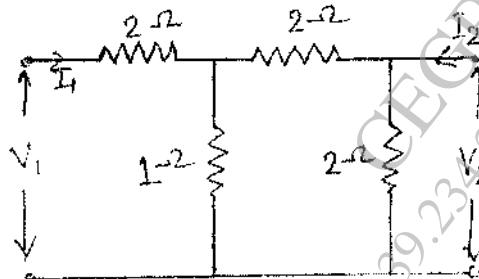

- (b) Find the driving point impedance for the network shown in figure. [7]

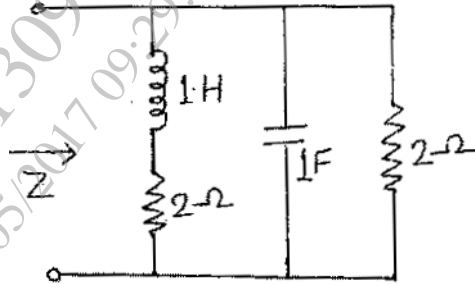

7. (a) Derive the expression for characteristic impedance (Z_0), attenuation constant (α) and phase constant (β) of prototype constant-K type low pass filter from symmetrical networks. [6]
- (b) Design a T and π section Constant-K low pass filter having cut-off frequency of 2KHz and design impedance $R_0 = 600\Omega$. Also find : [6]
- (i) Its characteristic impedance at 12 KHz and
- (ii) Attenuation at 4 KHz.

Or

8. (a) Explain the following terms in relation with filter : [6]
- (i) Pass band
- (ii) Stop band
- (iii) Cut-off frequency.
- (b) Design constant K-low pass filter to have a cut-off frequency of 796 Hz when terminated in a 600Ω resistance, in both the T and π configurations. [6]