

Total No. of Questions : 8]

SEAT No. :

P2915

[Total No. of Pages : 3

[5669]-504

T.E. (Civil) (Semester - I)
STRUCTURAL ANALYSIS - II
(2015 Pattern)

Time : 2½ Hours]

[Max. Marks : 70

Instructions to the candidates:

- 1) Solve Q.1 or Q.2, Q.3 or Q.4, Q.5 or Q.6., Q.7 or Q.8.
- 2) Figures to the right indicate full marks.
- 3) Use of non-programmable calculator is allowed.
- 4) Assume suitable data, if necessary.

Q1) a) Analyze the beam by Slope Deflection Method. Draw BMD [10]

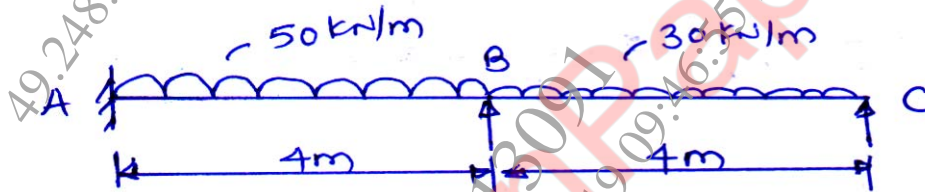

b) Analyze the beam by Moment Distribution Method. Draw BMD. [10]

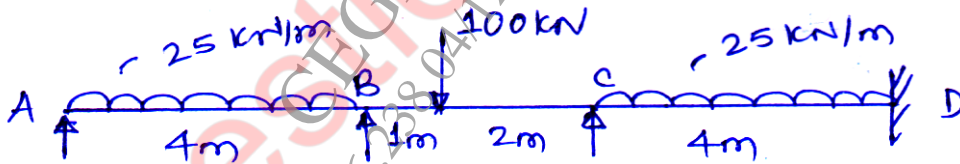

OR

Q2) a) Analyze the frame by slope deflection method. Draw BMD. [10]

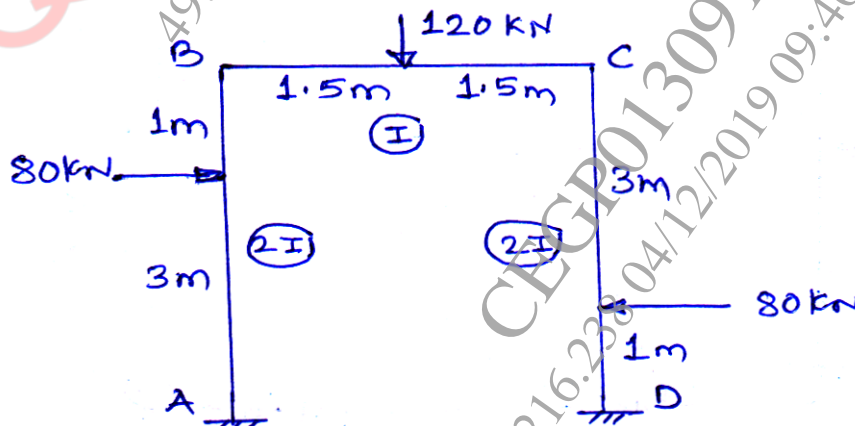

P.T.O.

b) Analyze the beam by Flexibility method. [10]

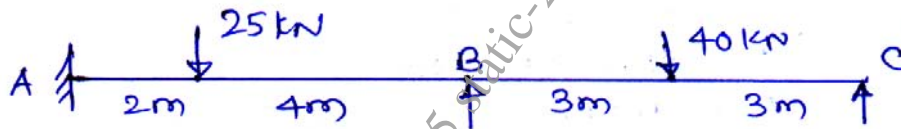

Q3) Analyze the beam by stiffness matrix method. Draw BMD. [16]

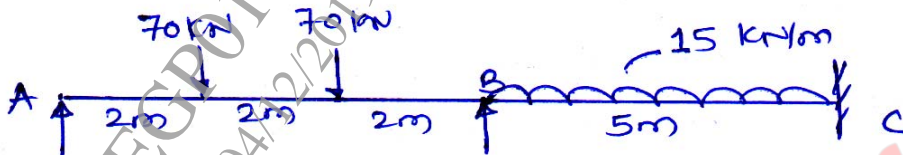

OR

Q4) Analyze the portal frame by stiffness matrix method. Draw BMD. [16]

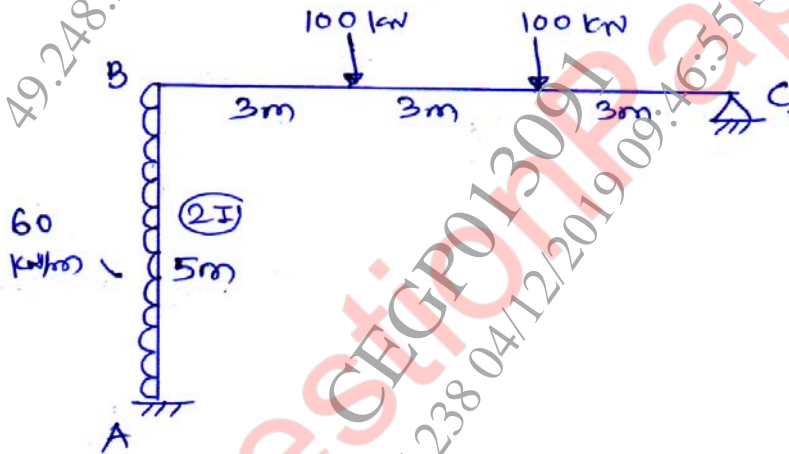

Q5) a) Analyze the frame by Portal Frame method. [10]

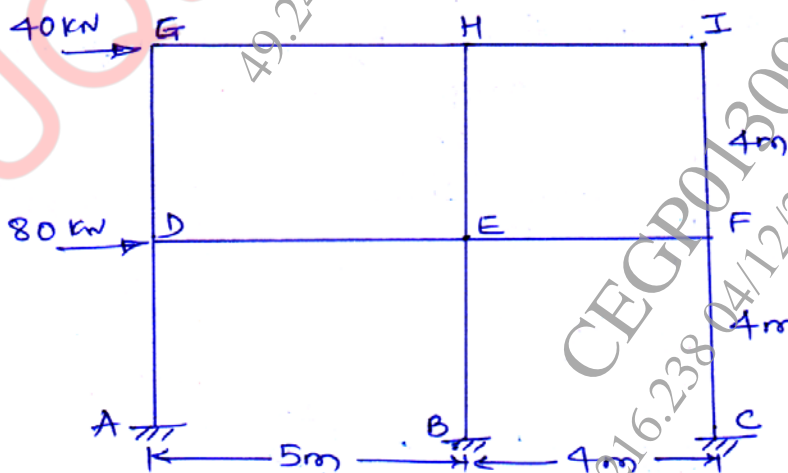

- b) A cantilever beam is loaded as shown. Find deflection under point loads. Take 5 nodes. [8]

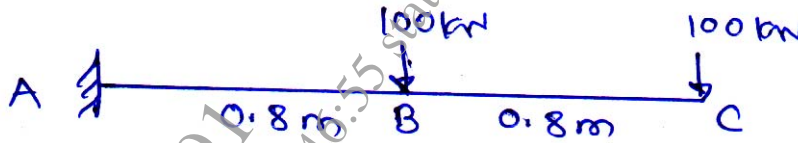

OR

- Q6) a) Analyze the frame given in Q.5 a) by cantilever method. [10]

- b) A simply supported beam is loaded with central point load of 110 kN. Span of the beam is 5m. Find deflection at nodes. (Take 5 nodes) [8]

- Q7) a) Explain following terms : [8]

- i) Isoparametric element
- ii) Co-ordinate systems
- iii) Subparametric element
- iv) Nodes

- b) Explain rectangular elements. [8]

OR

- Q8) a) Explain CST & LST. [8]

- b) Explain shape function and properties of shape function. [8]

▽▽▽▽