

Total No. of Questions : 8]

SEAT No. :

PC2780

[6352]-4

[Total No. of Pages :3

S.E. (Civil Engineering)

STRUCTURAL ANALYSIS

(2019 Pattern) (Semester- IV) (201011)

Time : 2½ Hours]

[Max. Marks : 70

Instructions to the candidates:

- 1) Answer Q.1 or Q.2, Q.3 or Q.4, Q.5 or Q.6, Q.7 or Q.8.
- 2) Neat diagrams must be drawn wherever necessary.
- 3) Figures to the right indicate full marks.
- 4) Assume suitable data, if necessary.
- 5) Use of electronic pocket calculator is allowed.

Q1) a) Analyze the beam shown in figure 1 by Slope Deflection Method. Draw BMD. [12]

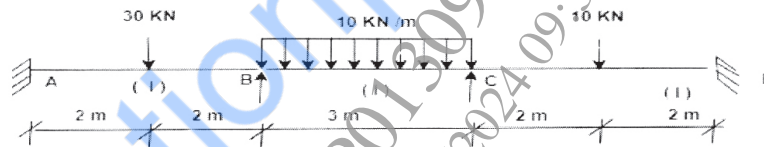

Figure 1

b) Analyze the beam shown in figure 2 by Slope Deflection Method. [5]

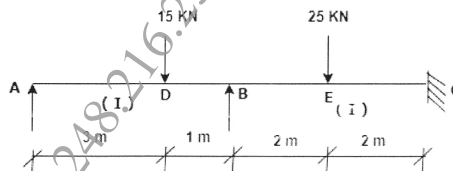

Figure 2

OR

Q2) Analyze the frame shown in figure 3 by Slope Deflection Method. Draw BMD. [17]

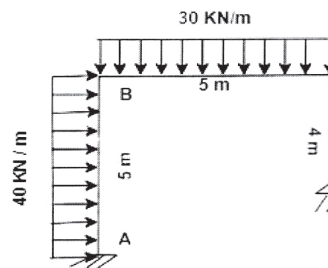

Figure 3

P.T.O.

- Q3) a) Analyze the beam shown in figure 4 by Moment Distribution Method. Draw BMD. [10]

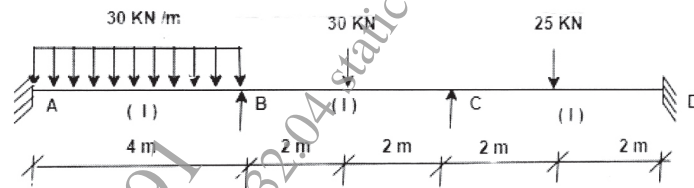

Figure 4

- b) Analyze the beam shown in figure 5 by Moment Distribution Method. [8]

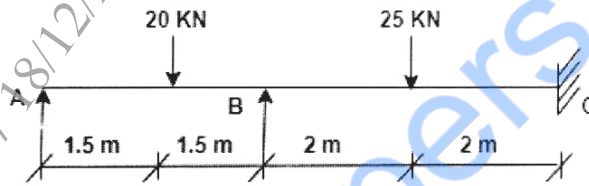

Figure 5

OR

- Q4) Analyze the frame shown in figure 6 by Moment Distribution Method. Draw BMD. [18]

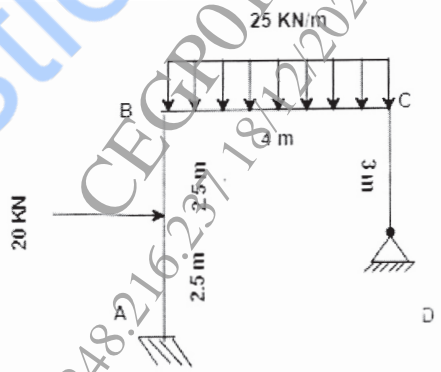

Figure 6

- Q5) a) Analyze the beam shown in figure 7 by Stiffness Matrix Method. [12]

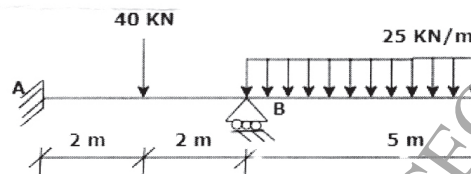

Figure 7

- b) Differentiate between stiffness matrix and displacement matrix. [5]

OR

Q6) Analyze the frame shown in figure 8 by Stiffness Matrix Method. [17]

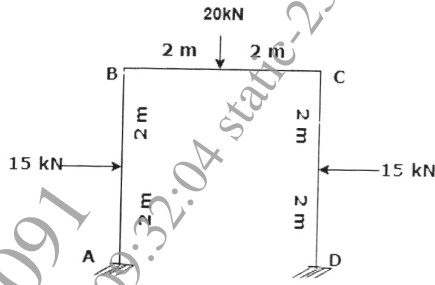

Figure 8

Q7) a) Explain different collapse mechanisms in plastic analysis. [5]  
 b) Determine plastic moment for the beam as shown in figure 9. [13]

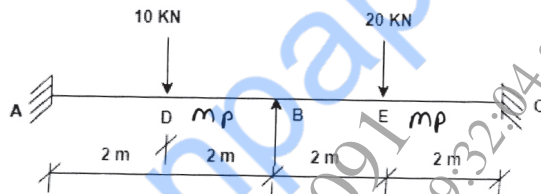

Figure 9

OR

Q8) a) Determine shape factor of I - Section Shown in figure 10. [12]

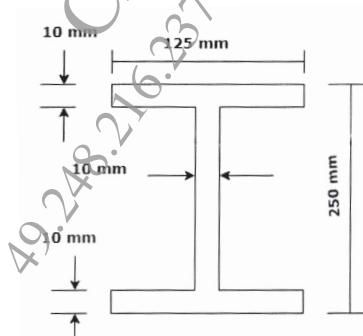

Figure 10

b) Define plastic hinge, load factor and shape factor. [6]

