

Total No. of Questions : 8]

SEAT No. :

P9079

[Total No. of Pages : 4

[6179]-204

S.E. (Civil)

STRUCTURAL ANALYSIS

(2019 Pattern) (Semester - IV) (201011)

Time : 2½ Hours]

[Max. Marks : 70

Instructions to the candidates:

- 1) Answer Q.1 or Q.2, Q.3 or Q.4, Q.5 or Q.6, Q.7 or Q.8.
- 2) Neat diagrams must be drawn wherever necessary.
- 3) Figures to the right indicate full marks.
- 4) Assume suitable data, if necessary.
- 5) Use of electronic pocket calculator is allowed.

Q1) a) Analyze the following beam shown in figure 1 by Slope Deflection Method. Draw BMD. [12]

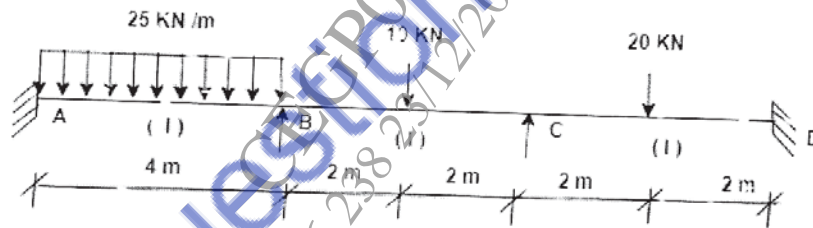

Figure 1

b) Analyze the bent shown in figure 2 by Slope Deflection Model. [5]

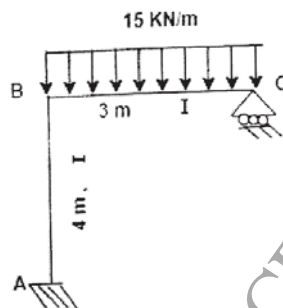

Figure 2

OR

P.T.O.

Q2) Analyze the frame shown in figure 3 by Slope Deflection Method. Draw BMD.[17]

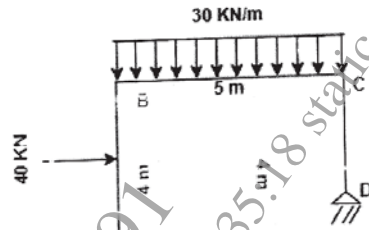

Figure 3

Q3) a) Analyze the beam shown in figure 4 by Moment Distribution Method. Draw BMD. [10]

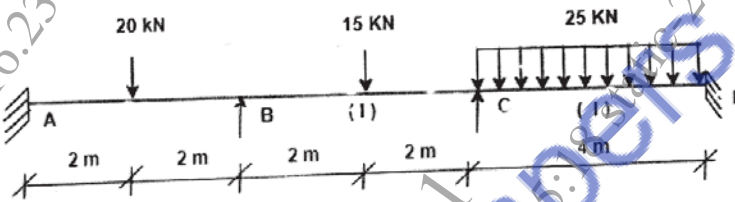

Figure 4

b) Analyze the bent shown in figure 5 by Moment Distribution Method.[8]

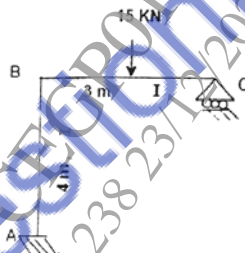

Figure 5

OR

Q4) Analyze the frame shown in figure 6 by Moment Distribution Method. Draw BMD. [18]

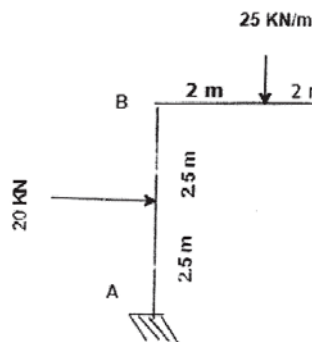

Figure 6

Q5) a) Analyze the beam shown in figure 7 by Stiffness Matrix Method. [12]

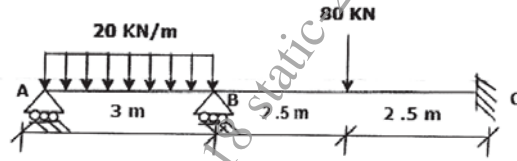

Figure 7

b) Explain stiffness and flexibility. [5]

OR

Q6) Analyze the frame shown in figure 8 by Stiffness Matrix Method. [17]

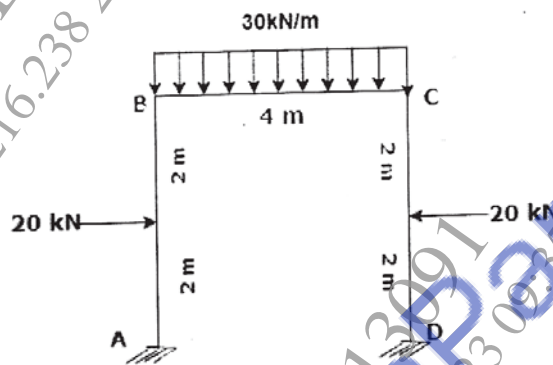

Figure 8

Q7) a) Write assumptions in plastic theory. [5]

b) Determine collapse load for the frame as shown in figure 9. [13]

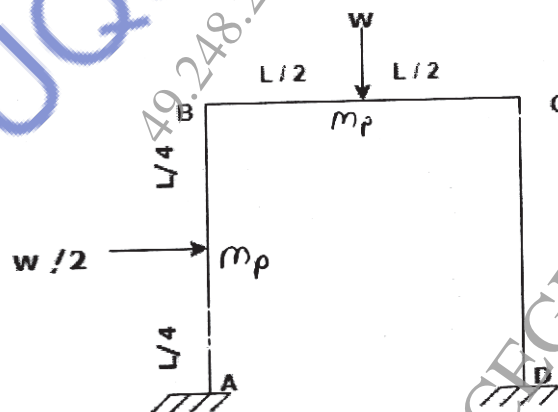

Figure 9

OR

Q8) a) Determine collapse load for the beam as shown in figure 10. [6]

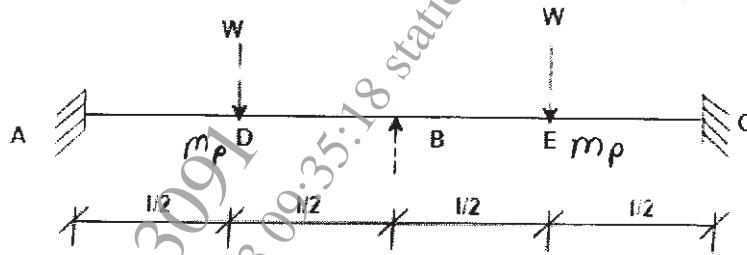

Figure 10

b) Determine shape factor of I-Section Shown in figure 11 [12]

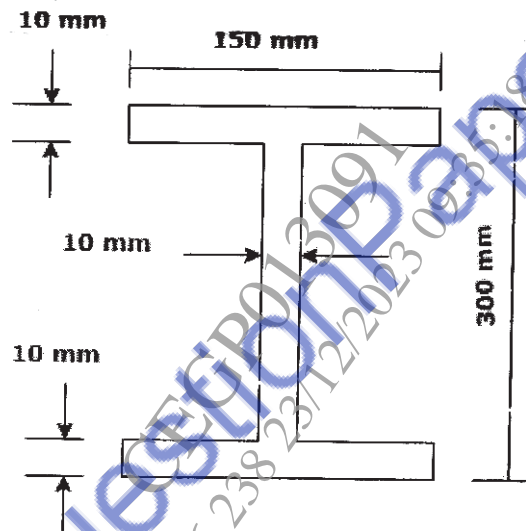

Figure 11

