

Total No. of Questions : 8]

SEAT No. :

PA-1187

[Total No. of Pages : 5

[5925]-209

S.E. (Civil)

STRUCTURAL ANALYSIS
(2019 Pattern) (Semester - IV) (201011)

Time : 2½ Hours]

[Max. Marks : 70

Instructions to the candidates:

- 1) Answer Q.1 or Q.2, Q.3 or Q.4, Q.5 or Q.6, Q.7 or Q.8.
- 2) Neat sketches must be drawn wherever necessary.
- 3) Figures to the right indicate full marks.
- 4) Assume suitable data, if necessary.
- 5) Use of electronic pocket calculator allowed.
- 6) Use of cell phone is prohibited in the examination hall.

Q1) a) Analyze the beam shown in figure 1 by slope deflection method and draw BMD. Assume uniform flexural rigidity. [12]

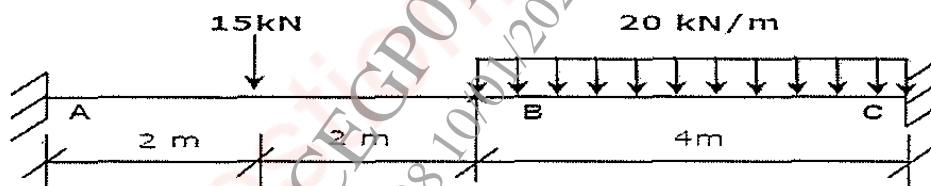

Figure 1

b) Find the rotation θ_B for the beam with uniform flexural rigidity as shown in figure 2. [6]

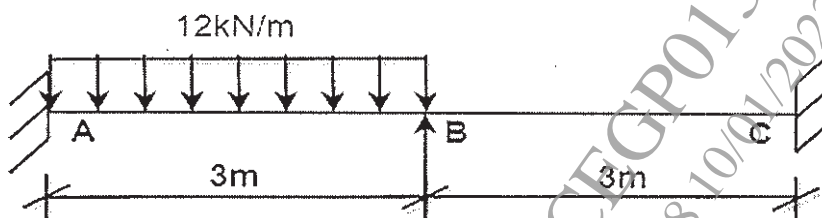

Figure 2

OR

P.T.O.

- Q2) a) Analyse the frame shown in figure 3 by slope deflection method and draw BMD. Assume uniform flexural rigidity. [12]

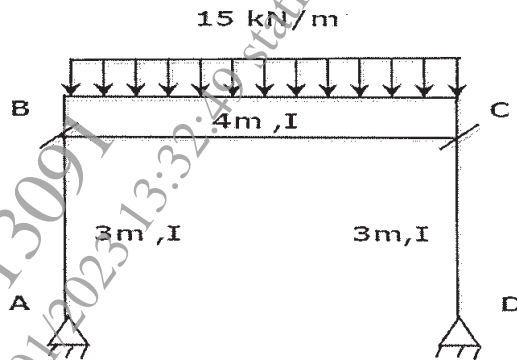

Figure 3

- b) Analyse the frame shown in figure 4 by slope deflection method. Assume uniform flexural rigidity. [6]

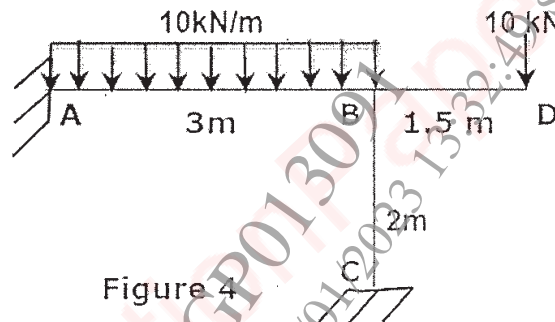

Figure 4

- Q3) a) Analyze the continuous beam ABCD shown in figure 5 by moment distribution method and draw BMD. Assume uniform flexural rigidity. [12]

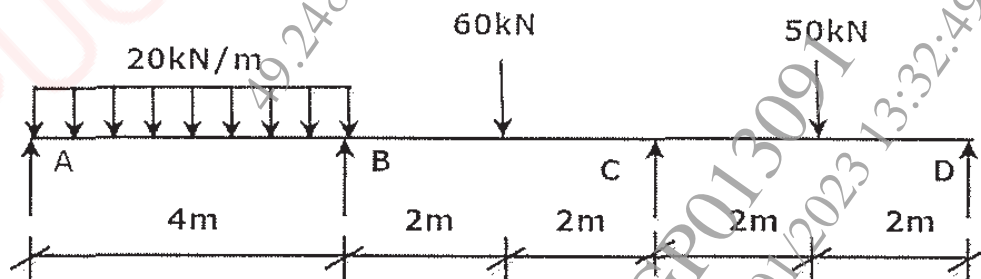

Figure 5

- b) Define member stiffness; carry over moment and distribution factor. [6]

OR

- Q4) a) Calculate final end moments for the frame shown in Fig. 6 by moment distribution method and draw BMD. [12]

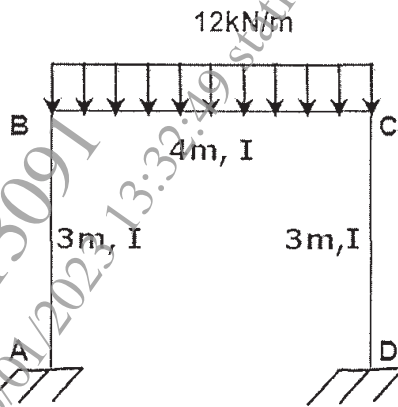

Figure 6

- b) Analyze bent ABC as shown in Fig. 7 by moment distribution method. [6]

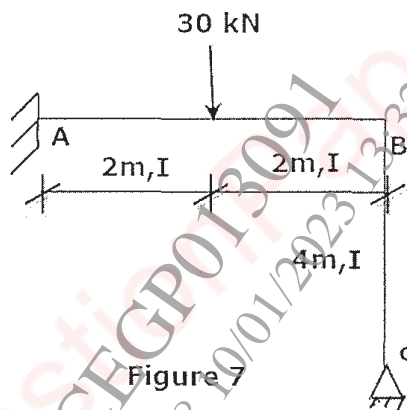

Figure 7

- Q5) a) Write note on stiffness method and write elements of displacement matrix for following figure. [6]

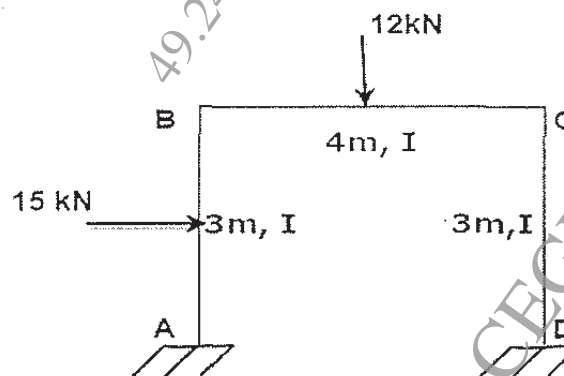

Figure 8

- b) Analyse the continuous beam ABCD as shown in Fig. 9 by stiffness method and draw bending moment diagram. Assume uniform flexural rigidity. [11]

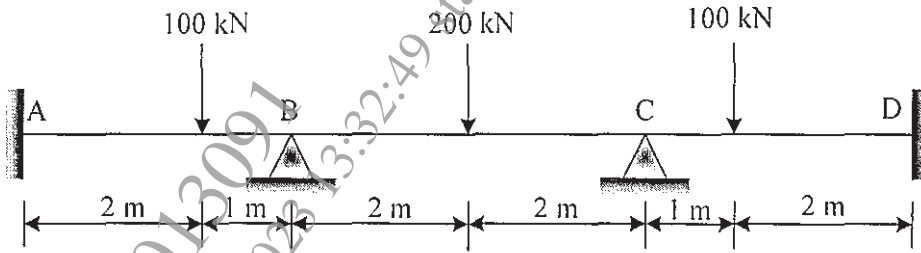

Fig. 9

OR

- Q6) a) Explain degrees of freedom and stiffness. [6]
 b) Analyse the bent shown in Fig.10 by stiffness method and draw bending moment diagram. [11]

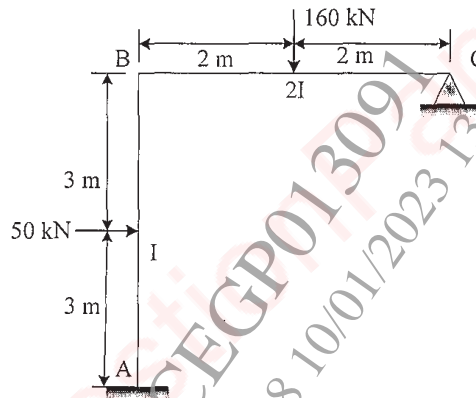

Fig. 10

- Q7) a) Define plastic hinge, load factor and shape factor. [6]
 b) Calculate the collapse load W_u , for the beam shown in figure 11. [11]

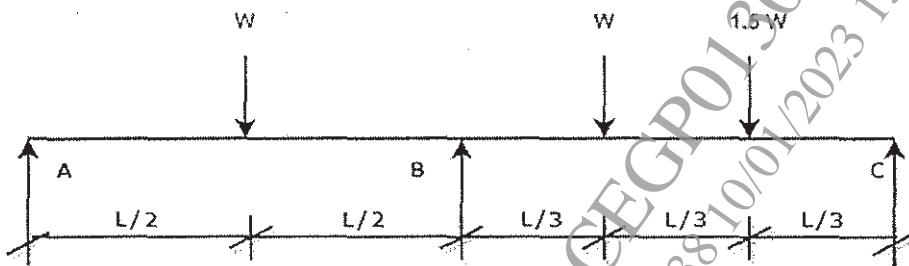

Figure 11

OR

- Q8) a) Explain different collapse mechanisms in plastic analysis with diagram. [6]
- b) Determine shape factor for I section shown in figure 12. [11]

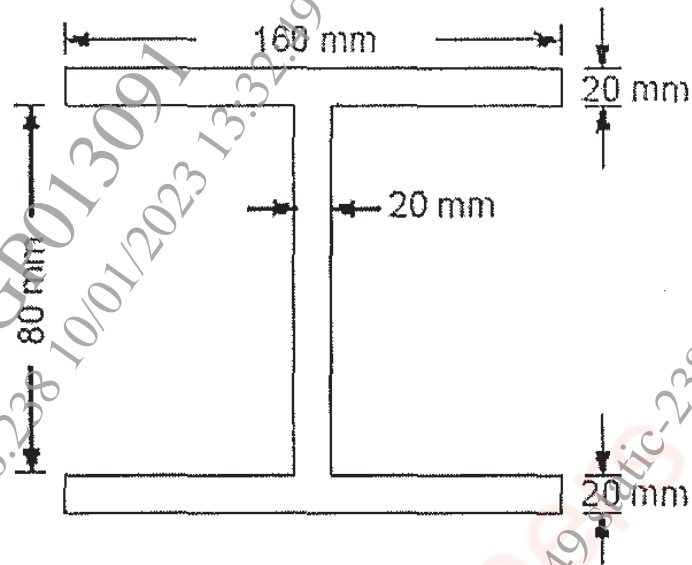

Figure 12

x x x