

Total No. of Questions—8]

[Total No. of Printed Pages—7

Seat No.	
----------	--

[5668]-109

S.E. (Civil) (Second Semester) EXAMINATION, 2019

STRUCTURAL ANALYSIS—I

(2015 PATTERN)

Time : Two Hours

Maximum Marks : 50

N.B. :— (i) Answer Question Nos. 1 or 2, 3 or 4, 5 or 6, 7 or 8.

(ii) Neat diagrams must be drawn wherever necessary.

(iii) Figures to the right indicate full marks.

(iv) Assume suitable data, if necessary.

(v) Use of electronic pocket calculator is allowed.

1. (a) Determine the deflection at the mid span of a simply supported beam shown in fig. 1 by using Conjugate beam method. Take constant value of EI. [6]

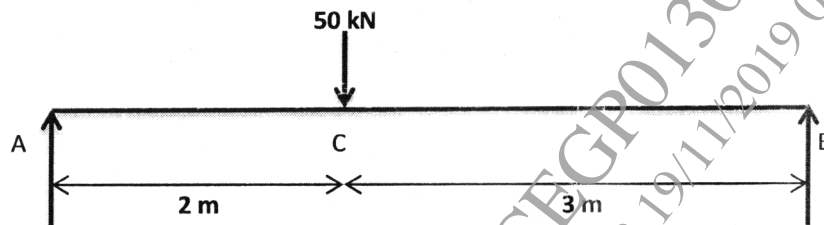

Fig. 1

P.T.O.

- (b) Determine the vertical deflection at free end of beam ABC shown in fig. 2 by using Castigliano's first theorem. Consider constant EI. [6]

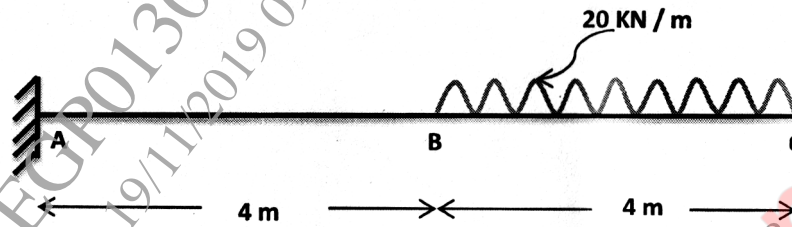

Fig. 2

Or

2. (a) Using Clapreyon's three moment theorem analyse the continuous beam ABC supported and loaded as shown in Fig. 3. [6]

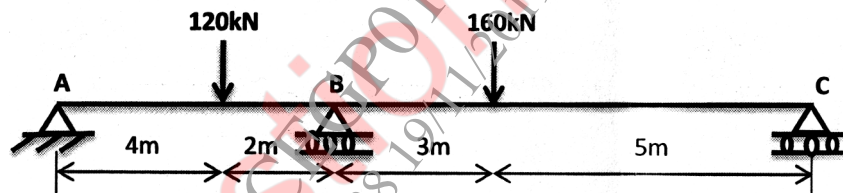

Fig. 3

- (b) Determine the reaction  $V_B$  for a continuous beam ABC shown in Fig. 4 by using Castigliano's second theorem. [6]

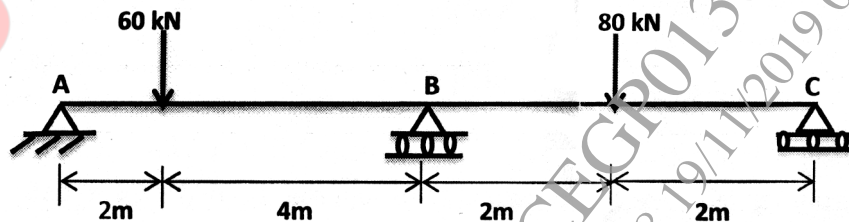

Fig. 4

3. (a) Find the vertical deflection of joint C of the pin jointed truss shown in Fig. 5. The cross-sectional area of horizontal member is  $1600 \text{ mm}^2$  and the c/s area of inclined member is  $2000 \text{ mm}^2$  each. Take  $E = 200 \text{ kN/mm}^2$ . [6]

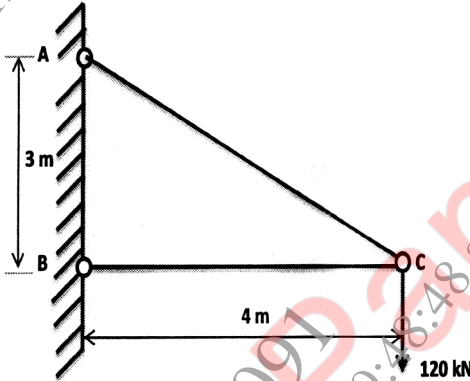

Fig. 5

- (b) Analyse the truss shown in Fig. 6. Take constant  $AE$ . [6]

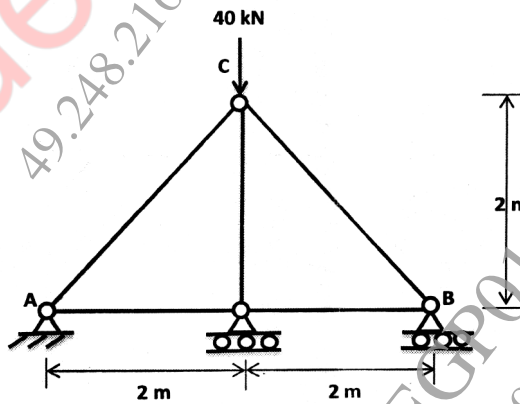

Fig. 6

Or

4. (a) Four equal loads of 80 kN each, equally spaced at 2 m apart followed by a uniformly distributed load of 60 kN/m run are placed as shown in Fig. 7. Using influence lines, calculate the shear force and bending moment at a section 8 m from left support A. [6]

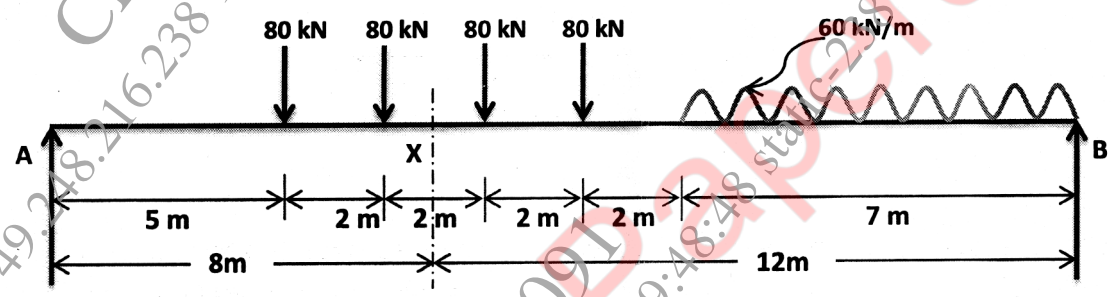

Fig. 7

- (b) Draw the influence line diagrams for the forces in the members  $U_2U_3$ ,  $U_2L_3$  and  $U_2L_2$  of the deck type bridge truss shown in Fig. 8. [6]

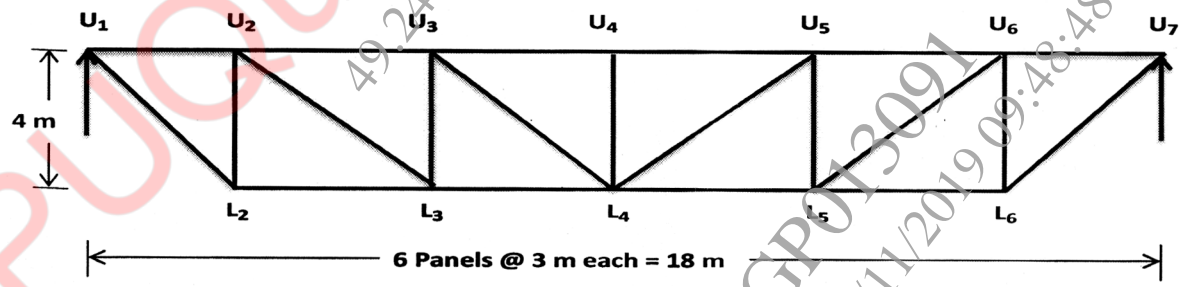

Fig. 8

5. (a) A three hinged parabolic arch of span 20 m and rise of 5 m. It carries a uniformly distributed load of intensity 20 kN/m over the left half of span and a point load of 120 kN at 5 m from the right end as shown in Fig. 9. Determine BM, Normal thrust and Radial shear at a section D, 4 m from the left support. [7]

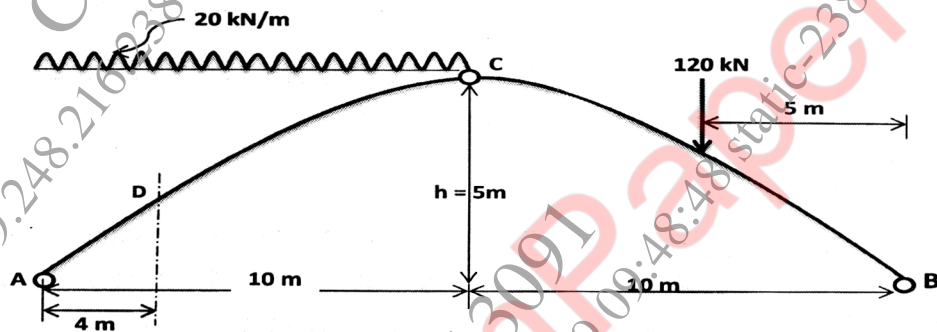

Fig. 9

- (b) Derive an expression for horizontal thrust when entire span of two hinged parabolic arch is loaded with uniformly distributed load of intensity  $w$  kN/m. [6]

Or

6. (a) A two hinged parabolic arch has a span of 60 m and a central rise of 10 m. It is subjected to a central point load of 40 kN at C as shown in Fig. 10. The second moment of area varies as the secant of the inclination of the arch axis. Determine the horizontal thrust developed and the reaction at the hinge

also calculate the Bending moment, Normal Thrust and Radial shear at a section 15 m from the left support A. [13]

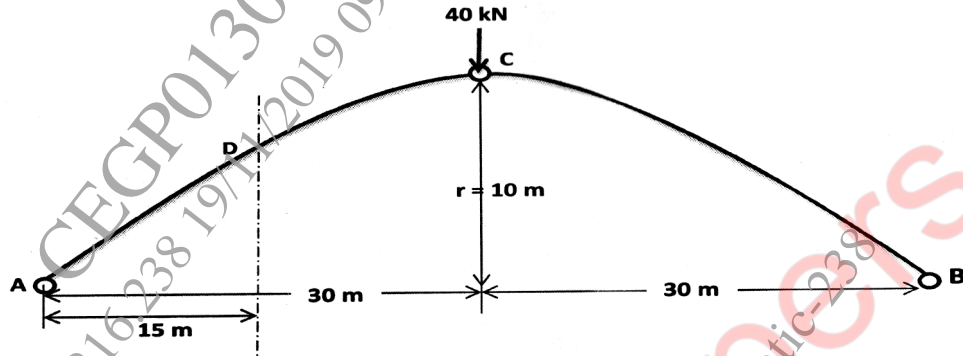

Fig. 10

7. (a) Determine the collapse load of the beam loaded as shown in Fig. 11. [8]

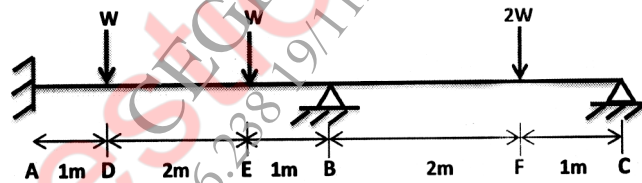
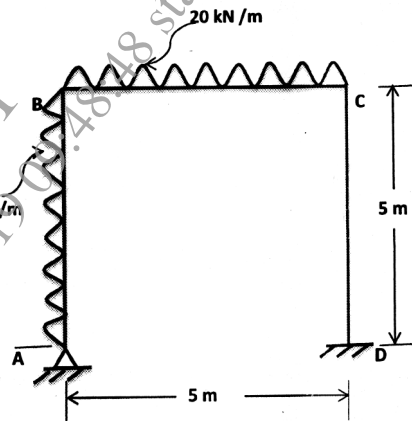

Fig. 11

- (b) State the assumptions of Plastic Theory. [5]

Or

8. (a) Fig. 12 shows a frame ABCD subjected to collapse load. Determine the plastic moment capacity of the section required. Assume the same section is going to be used throughout. [8]



**Fig. 12**

- (b) Explain the idealized and true stress-strain curve for mild steel in tension. [5]