

Total No. of Questions—8]

[Total No. of Printed Pages—4

Seat No.	
-------------	--

[5559]-102

S.E. (Civil) (I Sem.) EXAMINATION, 2019

STRENGTH OF MATERIAL

(2015 PATTERN)

Time : Two Hours

Maximum Marks : 50

Instructions: 1) Answer Q.1 or Q.2, Q.3 or Q.4 , Q.5 or Q.6, Q.7 or Q.8

2) Neat Sketches must be drawn wherever necessary.

3) Figures to the **right** indicate full marks.

4) Assume suitable data, if **necessary**.

5) Use of electronic pocket calculator is **allowed**.

6) Use of cell phone is prohibited in the examination hall.

1. a) A steel wire of length 600 mm is subjected to an axial pull of 10kN. Find the minimum diameter so that stress is not to exceed 75 Mpa. Also calculate the elongation if  $E=100\text{Gpa}$ . [06]

b) Maximum bending moment of simply supported beam is 25 kNm. The cross section of the beam is as shown in Fig. Find the maximum bending stress in tension and compression. [06]

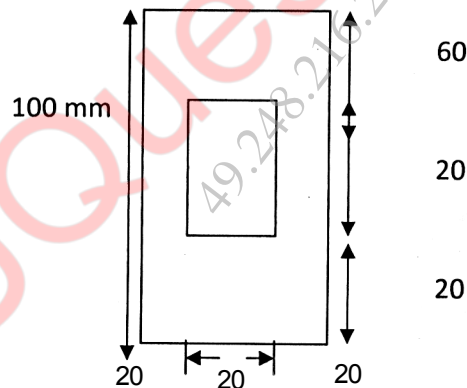

2. a) The concrete column is reinforced with six steel bars each of 22mm diameter. Knowing that rod is initially unstressed, determine normal stresses developed in steel and concrete.

Assume  $E_{\text{concrete}}=13.34\text{ Gpa}$ ,  $E_{\text{steel}}=200\text{ Gpa}$  and  $\alpha_{\text{concrete}}=5.2\times 10^{-6}/^{\circ}\text{C}$ ,  $\alpha_{\text{steel}}=12\times 10^{-6}/^{\circ}\text{C}$ . Assume column size =  $300\times 300\text{ mm}$ ,  $t=40^{\circ}$ . [06]

P.T.O.

b) A simply supported beam carries a uniformly distributed load of 30N/mm over the entire span of 1m. The cross section of the beam is a T section, with its top flange of 125X25 mm and web of 175X25 mm. Obtain the maximum shear stress and plot shear stress distribution. [06]

Q.3(a) A hollow shaft of 25mm outside diameter and 20mm inside diameter is subjected to a torque of 120Nm. Find the stress at outside and inside diameter of the shaft. [06]

(b) An element in a strained body is subjected to a tensile stress of 180 Mpa and shear stress of 50Mpa tending to rotate the element in a anticlockwise direction. Find [07]

(i) the magnitude of the normal and shear stresses on a section inclined at  $40^\circ$  with the tensile stress.

(ii) the magnitude and direction of maximum shear stress that can exist on the element.

Q4 a) A shaft of 100 mm diameter transmit 200 kW power at 200 rpm. At a section, bending moment is 5 KNm. Find the principle stresses, maximum shear stress and principle plane. [06]

b) A hollow shaft with ratio of internal diameter to external diameter  $\frac{3}{5}$  is required to transmit 450 kW at 120rpm with a uniform twisting moment. The shearing stress in the shaft must not exceed  $80 \text{ N/mm}^2$  and the twist in a length of 3 m must not exceed  $10^\circ$ . Taking  $G=8 \times 10^4 \text{ N/mm}^2$ , Determine the minimum external diameter of the shaft satisfying above two conditions. [07]

Q 5 a) Draw shear force and bending moment diagram for beam loaded as shown in Fig. [06]

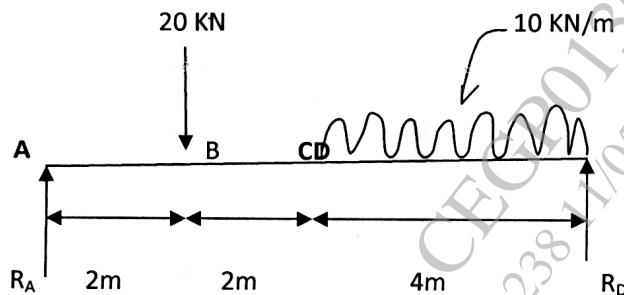

- b) Draw shear force and bending moment diagrams for an overhanging beam as shown in fig.2. Clearly indicate the point of contraflexure. [07]

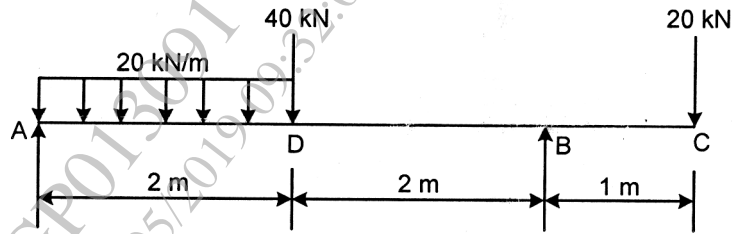

- Q 6 a) Draw the shear force and bending moment diagram for the beam shown in Fig. Mark the position of the maximum bending moment and determine its value. [06]

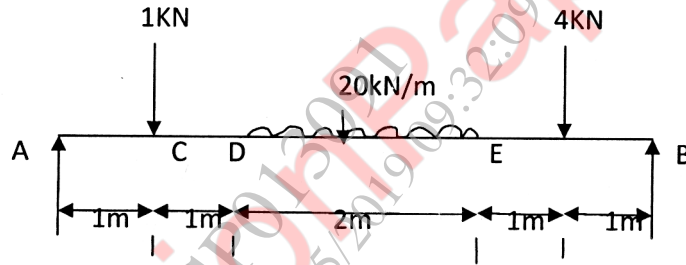

- b) Draw the bending moment diagram and loading diagram from given shear force diagram [07]

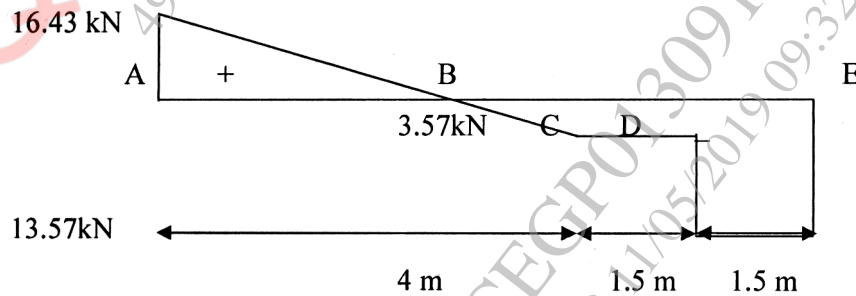

**Q 7 a)** A steel rod 6m long and 72 mm diameter is used as a column one end fixed and other free. Find crippling load by Euler's formula. Take  $E = 200 \text{ Gpa}$  [06]

**b)** A column  $1.2\text{m} \times 1.2\text{m}$  is subjected to an eccentric load  $600\text{kN}$  as shown in fig. Find the stresses at the corner A, B, C and D. Draw stress distribution diagram. [06]

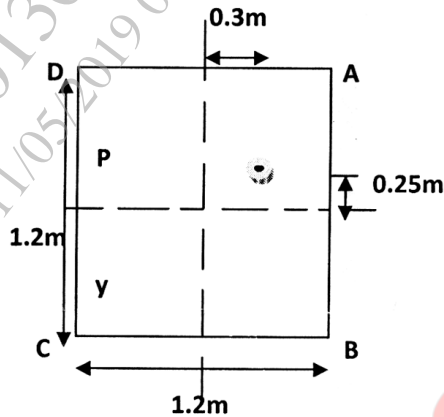

**Q 8 a)** Determine the crippling load for a hollow rectangular cast iron column of outer dimensions  $200\text{mm} \times 150\text{mm}$ , thickness of metal  $25\text{mm}$ , actual height of column  $6\text{m}$  with both ends fixed. Consider  $E = 180 \text{ Gpa}$ . [06]

**b)** A masonry pier  $3\text{m} \times 4\text{m}$  supports a vertical load of  $600\text{kN}$  at a point shown in the Fig. Find the stresses at the corners of the piers. Y [06]

